

Knife Coater Unit (Sharp Blade, J-Blade replaceable type)

The coating weight : 8~40g/m² (sharp blade), ~200g/m²(J-blade)

※In case of specific gravity 1.

Knife sharp can be changed by the consultation.

As the coating method, it can be a way of **Bed on Knife, Roll on knife, and Floating knife.**

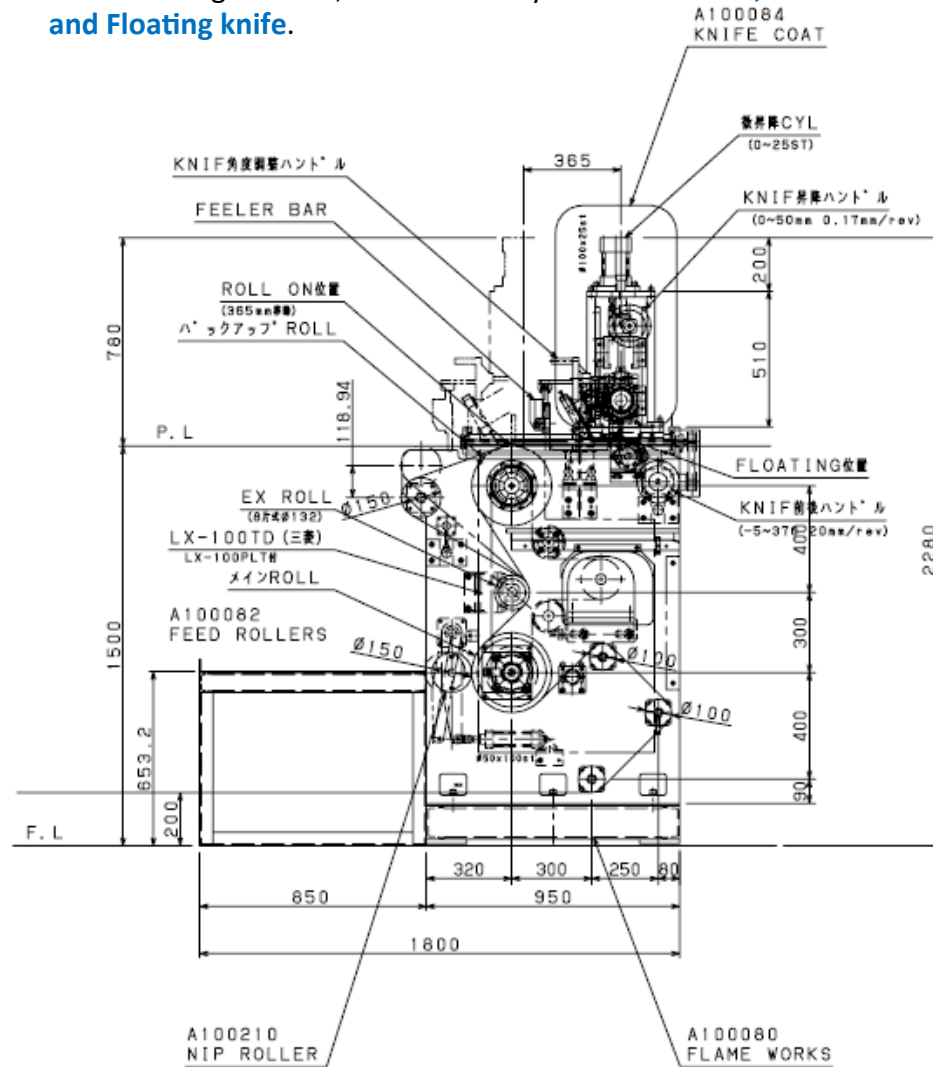

◆Equipment constitution specification

1. Coating unit

- Frame ; Steel plate and mold steel, workbench with frame 1 set
- Guide ring ; Guide roll, swivel tension and expander roll, etc. 1 set
- Main roll ; 300φmm SUS (2.2kw Vector Inverter Control) 1
- Backup roll ; 300φmm Surface hard chrome plating (with drive) 1
- Resin box ; SUS and Teflon plate 1 set
- KNIF DOCTOR ; Sharp blade SUS304 (tip thickness 0.5mm) 1
; clearance adjustment handle type (-30mm~+50mm)
; Display Dial gauge (L/R, scale 1/100mm)

- Cloth back ironing ; SUS doctor 1 set
- Adjusting Device ; Knife adjustment up and down, front and rear the control

positioning device(with scale plate)

- Product plate follow-up ; Selvage automatic control device (detector filler) 1 set
; Resin catch plate 1

2. Resin supply device (OPTION/not included in the Estimate)

- Tank transport truck 1
- Resin Automatic supply air pump (with air pressure reducing valve cock) 1
- Supply pipe 1 set

